

saas power moon

CONCRETE INSTRUCTIONS

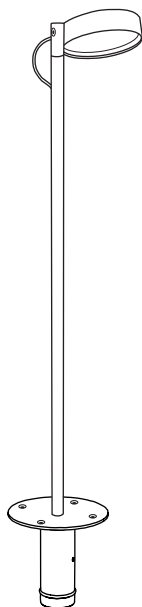



Power moon light fixture with casting adapter



Mounting ring



Electrical pipe

LED 7W	Ra 90	3 SDCM	600 lumen	350 mA	IP65	DIM
DMX	DALI	 -20°C...+50°C		L90B10 50 000h		

1

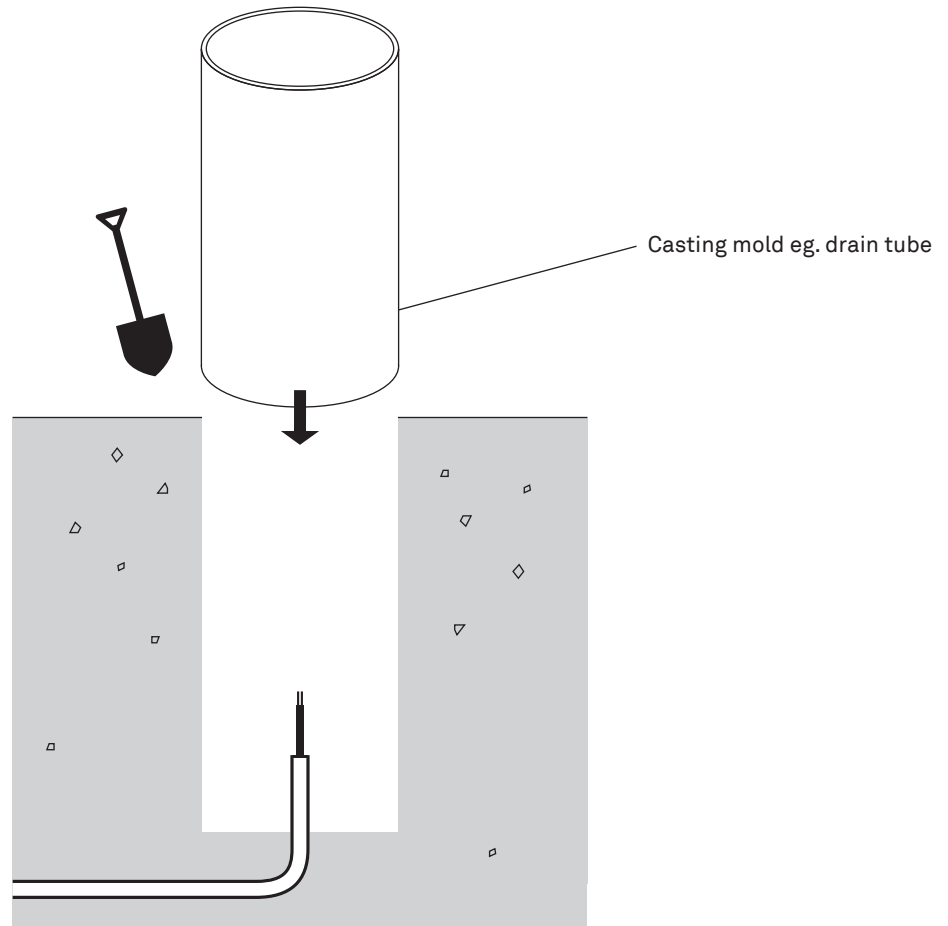

2

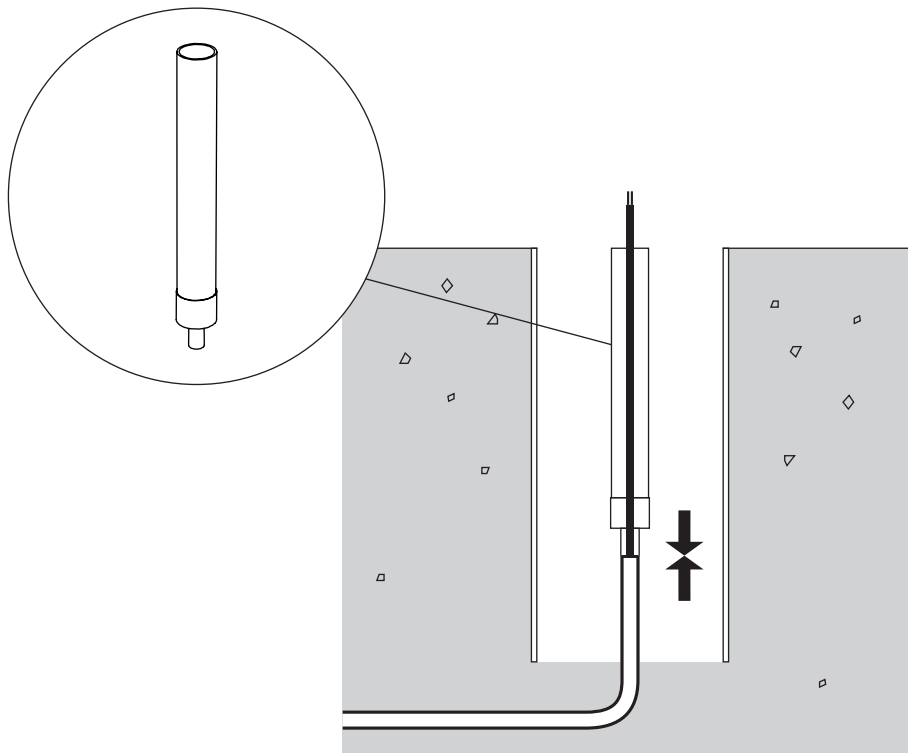

3

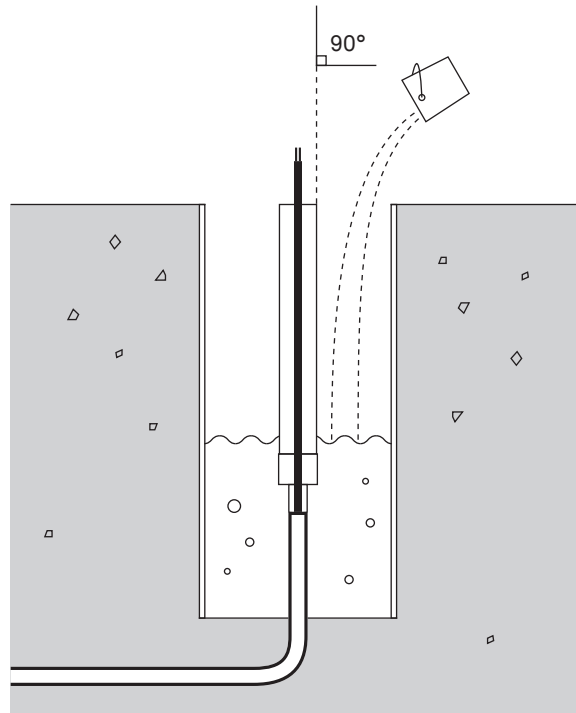

4

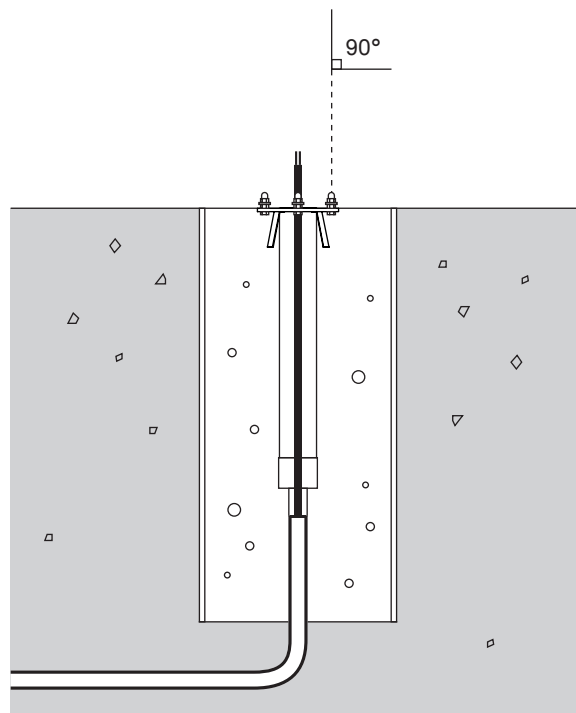

Mounting ring and pipe edge are casted in on exact same level. Hat nut and nuts stay on the screw while casting to prevent the thread from getting stuck by concrete.

Cast the Electrical Pipe as straight as possible. Only small angle adjustments are possible later!

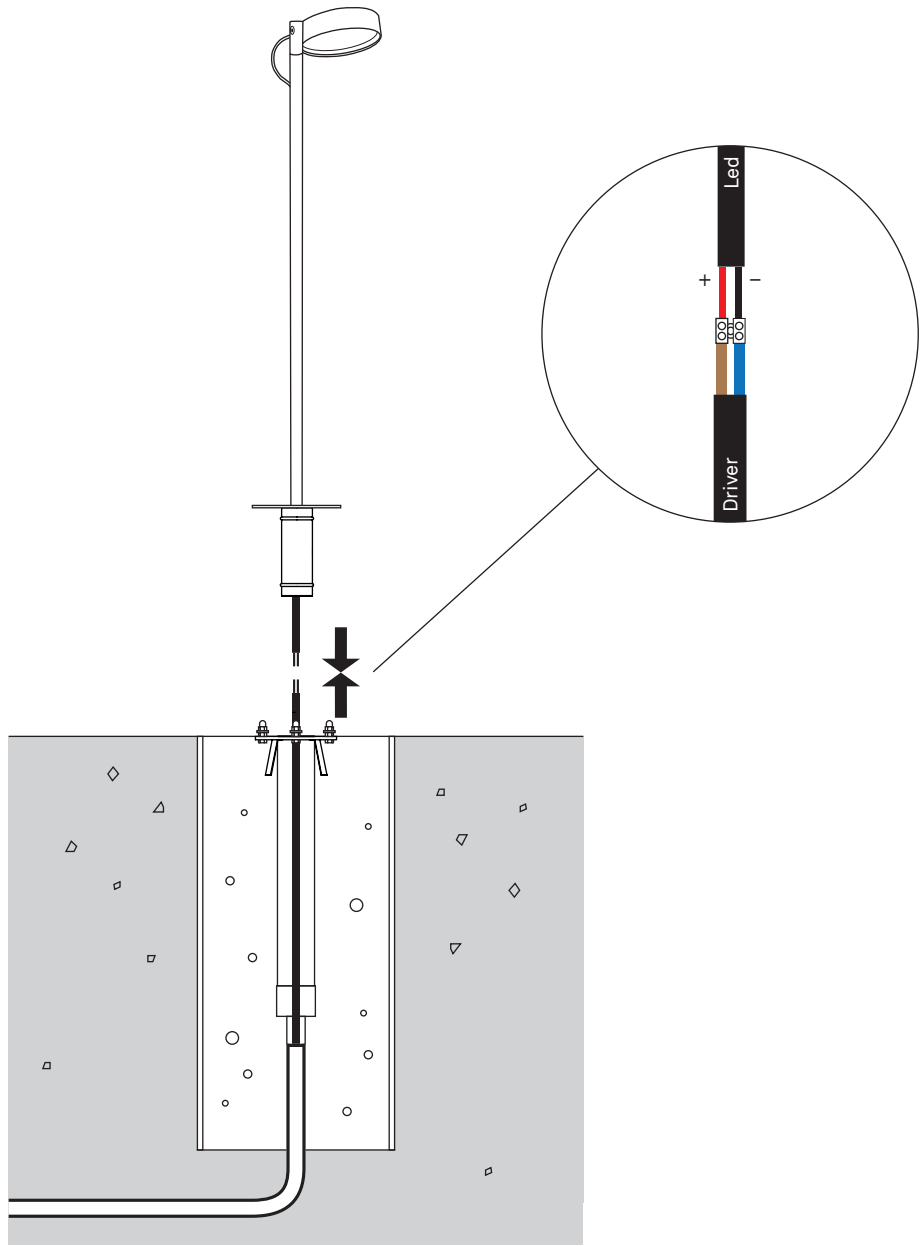

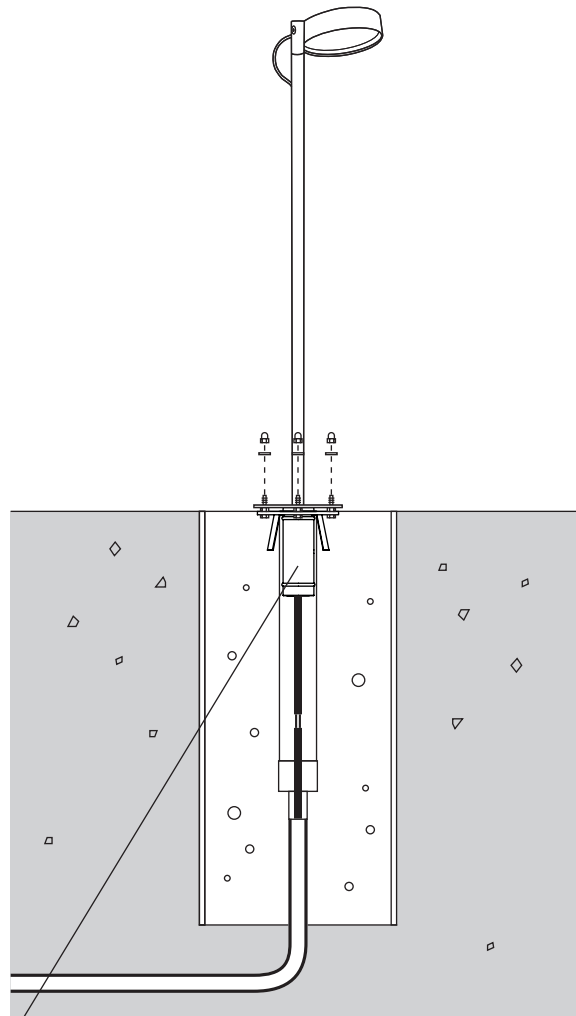

After connecting the cables the light fixture is pushed into the pipe and secured with the hat nuts.

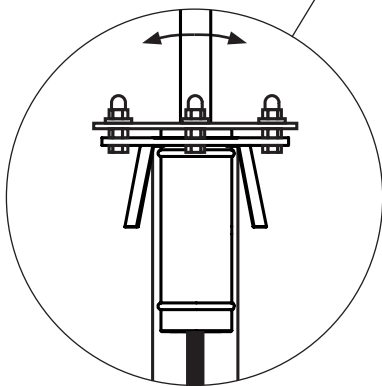

Raise the nuts under the disc to fine adjust the angle of the light fixture. Then tighten up the hat nuts on top of the washers.

